

## Revision 3 solutions

### - Electroplating.

1) An iron spoon is to be electroplated with a layer of silver metal. An electroplating cell is set up as shown on the right.

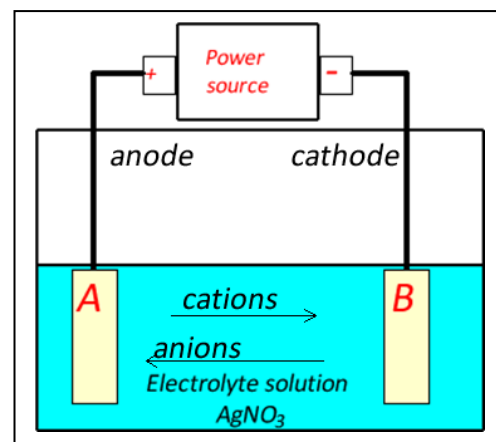

- Identify the anode and cathode.
- What should be placed at electrode "A"? *Silver metal*
- What should be placed at electrode "B"? *The spoon*
- On the image on the right, indicate the direction of anion and cation movement. Clearly label each.
- How does the  $[Ag^+]$  change as the cell operates?  
*It remains constant*
- Write the half reaction that takes place at the:
  - Anode -  $Ag(s) \rightarrow Ag^+(aq) + e$
  - Cathode  $Ag^+(aq) + e \rightarrow Ag(s)$

g) The electroplating cell is left running for 2.40 hours at a current of 2.35 amps and a voltage of 10.3 volts. What mass of silver is deposited in this time?

*Step 1 Find the mol of electrons delivered in 2.40 hours*

$$\Rightarrow Q = It = 2.35 \times 2.40 \times 60 \times 60 = 20304 \text{ C}$$

$$\Rightarrow n_e = 20304 / 96500 = 0.210$$

*Step 2 find the mol of silver*

$\Rightarrow Ag^+(aq) + e \rightarrow Ag(s)$  according to the reduction reaction occurring at the cathode for every mol of electrons delivered one mol of silver is deposited.

$$\Rightarrow n_{Ag} = 0.210$$

*Step 3 Find the mass of silver*

$$\Rightarrow \text{mass} = 0.210 \times 107.9 = 22.7 \text{ grams}$$

h) Another spoon is placed in the electroplating cell where a current of 2.35 amps is delivered. A volume of  $12.1 \text{ cm}^3$  of silver is to be plated onto the spoon. If the density of silver is  $10.5 \text{ g/cm}^3$  calculate the mass of silver .

$$\text{Mass} = \text{density} \times \text{volume}$$

$$\Rightarrow 12.1 \times 10.5 = 127.1 \text{ g}$$

- number of mol of electrons needed to deposit this mass of silver  
 $n_{Ag} = 127.1 / 107.9 = 1.18 \text{ mol} = n_e = 1.18 \text{ mol}$
- time, days, needed to deliver the required mass of silver

*Step 1 find the charge needed*

$$\Rightarrow Q = n_e \times 96500 = 1.18 \times 96500 = 113870 \text{ C}$$

*Step 2 find the time it takes to deliver this amount of charge*

$$\Rightarrow t = Q/I = 113870 / 2.35 = 48455 \text{ seconds} = 0.561 \text{ days}$$

- 2) A new electroplating cell is set up by a student who wishes to electroplate copper metal onto his locker key.
- The setup on the right is constructed and allowed to run for 1.10 hours at a current of 5.50 amps and a voltage of 12.0 volts
- a) What is the concentration of the copper ions in the solution after the plating?

*The  $[Cu^{2+}]$  remains constant. For every  $Cu^{2+}$  reduced at the cathode another  $Cu^{2+}$  ion is formed at the anode.*

- b) What mass of copper, in grams, is deposited on the key.

*At the cathode the following reaction takes place*



*for every two mol of electrons delivered one mol of copper is formed.*

*Step 1 find the mol of electrons delivered*

$$\Rightarrow Q = It = 5.50 \times 1.10 \times 60 \times 60 = 21780 \text{ C}$$

$$\Rightarrow n_e = 21780 / 96500 = 0.226$$

*Step 2 find the mol of copper*

$$\Rightarrow n_{Cu} = 0.226 / 2 = 0.113 \text{ mol}$$

*Step 3 find the mass of copper*

$$\Rightarrow 0.113 \times 63.5 = 7.18 \text{ grams}$$

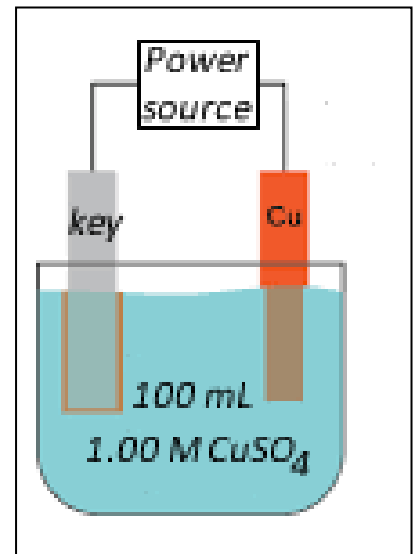

- c) Another student devised the setup shown on the right. What is the concentration of the copper ions in the solution after the plating?

*Since the copper ions taken out of solution are not replaced the concentration of  $Cu^{2+}$  will decrease.*

*Step 1 find the initial mol of  $Cu^{2+}$  in the original solution.*

$$\Rightarrow n = C \times V \Rightarrow 2.00 \times 0.100 = 0.200 \text{ mol}$$

*Step 2 find the mol  $Cu^{2+}$  remaining.*

$$\Rightarrow 0.200 - 0.113 = 0.087 \text{ mol}$$

*Step 3 find the new  $[Cu^{2+}]$*

$$\Rightarrow 0.087 / 0.100 = 8.87 \times 10^{-3}$$

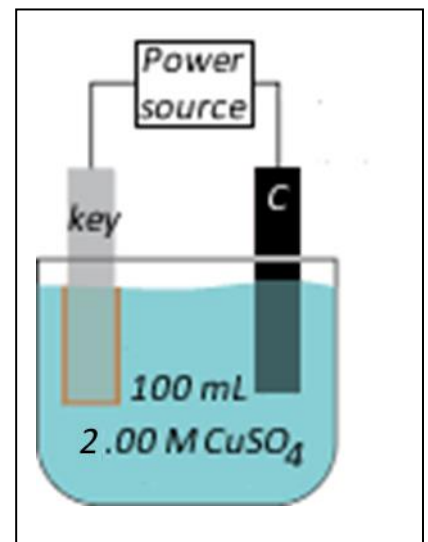

3) A metal consisting of a mixture of metals forms one of the electrodes of an electroplating cell, the other electrode is composed of carbon. The mixture of metals includes iron, copper, tin, zinc and gold. The cell voltage is set so that tin only is deposited at the carbon electrode, all other metals are either dissolved as cations in the solution or fall to the bottom as a sludge. This ensures a pure tin sample is obtained.

a) What metals can be found in the solution as cations. Explain

*Since tin is oxidised at electrode "A" all reductants stronger than tin will also be oxidised. Fe and Zn will undergo oxidation along with Sn.*

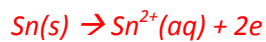
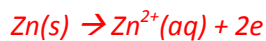
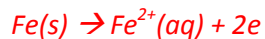

b) What metals should be found in the sludge? Explain

*Metals that are weaker reductants than tin will remain as metals eg Au and Cu and fall to the bottom as a sludge. if Au or Cu were oxidised the  $\text{Au}^{2+}$  or  $\text{Cu}^{2+}$  ions would find their way into the solution and react with the Sn being deposited on the cathode ( carbon electrode).*

$\text{Au}^+(\text{aq}) + \text{e}^- \rightleftharpoons \text{Au(s)}$
$\text{Cl}_2(\text{g}) + 2\text{e}^- \rightleftharpoons 2\text{Cl}^-(\text{aq})$
$\text{O}_2(\text{g}) + 4\text{H}^+(\text{aq}) + 4\text{e}^- \rightleftharpoons 2\text{H}_2\text{O(l)}$
$\text{Br}_2(\text{l}) + 2\text{e}^- \rightleftharpoons 2\text{Br}^-(\text{aq})$
$\text{Ag}^+(\text{aq}) + \text{e}^- \rightleftharpoons \text{Ag(s)}$
$\text{Fe}^{3+}(\text{aq}) + \text{e}^- \rightleftharpoons \text{Fe}^{2+}(\text{aq})$
$\text{O}_2(\text{g}) + 2\text{H}^+(\text{aq}) + 2\text{e}^- \rightleftharpoons \text{H}_2\text{O}_2(\text{aq})$
$\text{I}_2(\text{s}) + 2\text{e}^- \rightleftharpoons 2\text{I}^-(\text{aq})$
$\text{O}_2(\text{g}) + 2\text{H}_2\text{O(l)} + 4\text{e}^- \rightleftharpoons 4\text{OH}^-(\text{aq})$
$\text{Cu}^{2+}(\text{aq}) + 2\text{e}^- \rightleftharpoons \text{Cu(s)}$
$\text{Sn}^{4+}(\text{aq}) + 2\text{e}^- \rightleftharpoons \text{Sn}^{2+}(\text{aq})$
$\text{S(s)} + 2\text{H}^+(\text{aq}) + 2\text{e}^- \rightleftharpoons \text{H}_2\text{S(g)}$
$2\text{H}^+(\text{aq}) + 2\text{e}^- \rightleftharpoons \text{H}_2(\text{g})$
$\text{Pb}^{2+}(\text{aq}) + 2\text{e}^- \rightleftharpoons \text{Pb(s)}$
$\text{Sn}^{2+}(\text{aq}) + 2\text{e}^- \rightleftharpoons \text{Sn(s)}$ <span style="color:red">←</span>
$\text{Ni}^{2+}(\text{aq}) + 2\text{e}^- \rightleftharpoons \text{Ni(s)}$
$\text{Co}^{2+}(\text{aq}) + 2\text{e}^- \rightleftharpoons \text{Co(s)}$
$\text{Fe}^{2+}(\text{aq}) + 2\text{e}^- \rightleftharpoons \text{Fe(s)}$
$\text{Zn}^{2+}(\text{aq}) + 2\text{e}^- \rightleftharpoons \text{Zn(s)}$